

# DNA Structure: Gumdrop Modeling

## Student Advanced Version

In this 4-part lab, students will get an up-close and personal look at DNA, including its structure, how that structure is important for its replication, and how it is packaged and regulated.

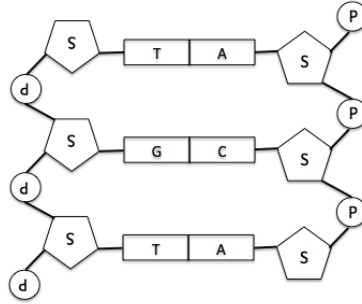

### Key Concepts:

- DNA is made of strings of **nucleotides**. A nucleotide is a chemical molecule composed of one phosphate group, one sugar ring, and one nitrogen-containing base.
- DNA has 4 types of **bases**: Adenine, Thymine, Cytosine, and Guanine (A, T, C, and G). These bases have strict binding rules, as A only bonds with T (and vice versa), and C only bonds with G. This is important for DNA replication to work.
- DNA is carefully packaged in the nucleus to compact it, protect it, and control which parts of the DNA are turned on and off in different cells.

## Part 1 – Building a DNA Molecule

In this section, we will build DNA models in order to understand what a *nucleotide* is composed of, and how several nucleotides fit together into a DNA molecule.

1. Separate the two bags of candy you were given. Set one bag aside. Empty out the second bag, and create 6 nucleotides using toothpicks and the following key:

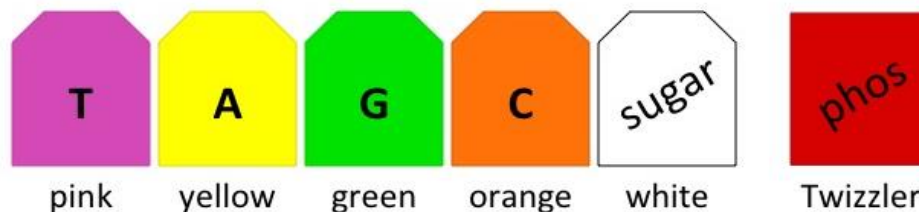

Q1. What are the three parts of a nucleotide? Please draw and label below.

2. Once you have your 6 nucleotides, pick up one of your “A” nucleotides (yellow).

Q2. What is the complementary (matching) base for “A”? What color is that base?

3. Use a toothpick to bond the “A” nucleotide with its complementary nucleotide. Note that they should be connected just through the **base**. Also, if one nucleotide has the phosphate pointing *up*, then the paired nucleotide should have the phosphate point *down*, indicating opposite orientations (like the lanes on a street).
4. Repeat with the remaining nucleotides, creating a total of 3 paired sets.
5. Now connect the three nucleotide pairs together, by attaching the phosphate group (Twizzler) of one nucleotide to the sugar (marshmallow) of the next.

Circle and label the backbone and the bases of the DNA molecule below

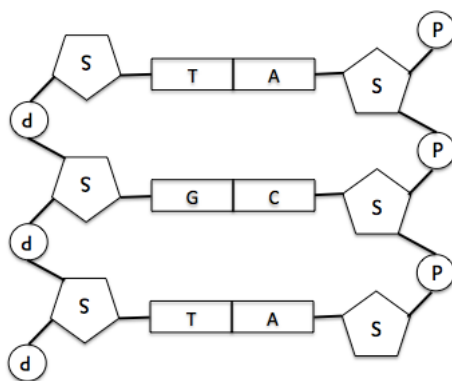

\* Your nucleotide pairs do not need to be in this exact order, as long as the A/T and C/G pairing are correct!

Great! You just made a model of a little piece of DNA. Almost all living things have DNA that looks just like this - from people to dogs to cacti! But if DNA contains the recipe for each of these very different creatures, then the DNA from each of them must be different *somehow*, right?

Let's look at an example.

The drawings below show a small section of DNA from three very different organisms: a plant, a mammal, and a bacterium. Each strand of DNA shown contains four nucleotide pairs.

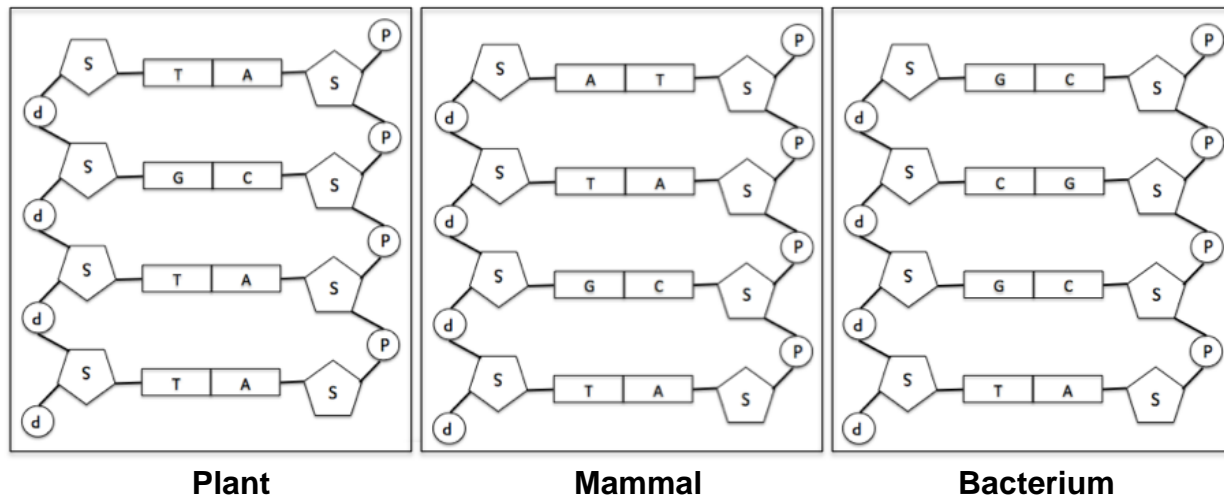

*Q3. What is different in the DNA of these different organisms? Complete the following table to identify what is different between the DNA of the plant, mammal, and bacterium.*

	<b>Compare the plant and mammal DNA.</b>	<b>Compare the mammal and bacterium DNA.</b>
Is the arrangement of the sugar and phosphate groups the same in each type of DNA?		
Does each type of DNA contain the same four bases ( <b>A, C, G, T</b> )?		
Is the order of the bases (read from top to bottom) the same in each type of DNA?		
Are the base-pairing rules ( <b>A/T</b> and <b>C/G</b> ) the same in each type of DNA?		

(adapted from [http://serendip.brynmawr.edu/sci\\_edu/waldron/](http://serendip.brynmawr.edu/sci_edu/waldron/))

*Q4. What is the only characteristic that differs between these segments of DNA from a plant, a mammal, and a bacterium?*

## Part 2 – DNA Replication

You have now completed a DNA model. However, DNA is not an unchanging molecule! Every time one cell divides into two (for example, to make new skin cells that are needed to heal a cut), both cells need their own copies of the DNA. How does this happen?

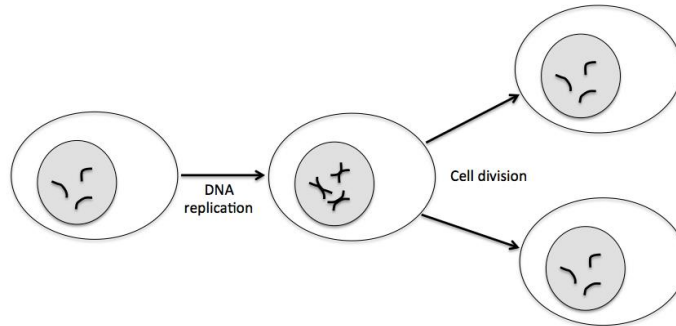

To make one DNA molecule into two, the bonds between the bases (the rungs of the ladder) are broken by an enzyme called **DNA helicase** (depicted as scissors below). Once the strands are separated, newly made nucleotides can be brought in and paired up with each individual strand by another enzyme, **DNA polymerase** (depicted as grey ovals), which knows the base pairing rules (A/T and C/G). When they're done, you have two complete copies of DNA, ready to be divided into two new cells!

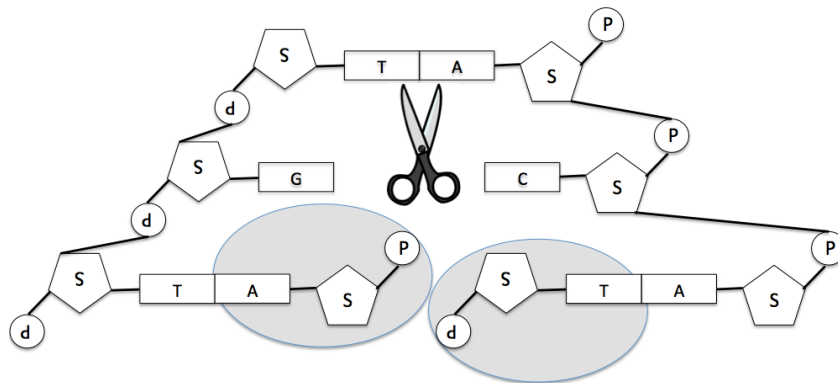

1. Take the scissors and cut your model through the middle, between the colored bases (be careful!).

*Q5. What part of the replication process do the scissors represent?*

2. Using the bag of extra candies, make 6 new nucleotides, each consisting of 1 phosphate, 1 sugar, and 1 base (make sure to pick the right nucleotides that will pair with your DNA strands!)

3. Convert each half-strand of DNA into completed strands by attaching the correctly paired base to each splintered end, making sure to remember the opposite orientation of the phosphate groups!

*Q6. What enzyme are you representing now?*

*Q7. You just replicated 3 nucleotide pairs in a matter of a few minutes. However, the DNA polymerase in bacteria can replicate 2,000 nucleotides per **second**! The reason that DNA polymerase needs to travel so fast is because a real bacteria cell doesn't just have 3 nucleotide pairs – it has 5,000,000! How many seconds would it take DNA polymerase to replicate 5,000,000 nucleotides, if it does 2,000 nucleotides per second? How many minutes is this?*

Now you have two complete DNA strands, ready to be handed down into new cells!

*Q8. What is a mutation? Using your model, can you explain how errors in DNA replication could lead to mutations in later generations of cells?*

*Q9. Mutations often arise when DNA is damaged. Can you think of things in your environment (or in your own body) that can damage DNA?*

## Part 3 – DNA Extraction

(Adapted from <http://genetics.thetech.org/online-exhibits/do-it-yourself-strawberry-dna>)

Now that we know what DNA looks like on the molecular (microscopic) level, let's see what real DNA looks like with just your eyes!

We know that DNA is stored in the cell **nucleus**. So how do we get it out? Actually, if you put cells in liquid with lots of salt and detergent, they will **lyse** or pop, releasing the DNA into the liquid around them!

1. Mix together your extraction solution in a measuring cup (make sure to scale up, if necessary, to have at least 4 Tbsp per group). For 3-4 groups:
  - 1 tsp salt
  - 2/3 c water
  - 2 Tbsp dish detergent
2. Place the funnel in the tall glass or cup, and line it with the cheese cloth or coffee filter.
3. Put three strawberries (no stems or leaves!) into a sandwich bag and seal it, squeezing all of the air out of the bag as you do so.
4. Squish the strawberries for about 2 minutes (enough to almost eliminate all clumps).
5. Add 4 Tbsp of the extraction solution to the strawberries. Push out all the air and seal the bag.
6. Squeeze the strawberry mixture for about 1 minute.

*Q10. What are you doing to the strawberry cells right now?*

7. Pour the strawberry mixture into the funnel, and let all of the liquid drain into the cup.

*Q11. Where is the DNA right now?*

8. Throw away the filter and the strawberry pulp.
  - Optional: Pour the liquid into a test tube until it's about 3/4 full (if you don't have test tubes, just leave the liquid in the cup).

9. Tilt the cup / test tube and *very slowly* pour cold rubbing alcohol along the side, letting it form a layer about 1cm thick on top of the strawberry extract. **DO NOT MIX THE ALCOHOL AND THE EXTRACT!**
10. Carefully hold the cup up to the light and look through the alcohol layer – can you see anything floating near the surface with the strawberries?
11. Dip a toothpick into the alcohol, gently touching where the two layers meet. Carefully pull up the skewer – the DNA should stick to it, and be pulled out as well.

*Q12. What does the DNA look like (long, short, clumpy, smooth, stretchy, brittle, etc)? What color is it? Looking at your DNA model, why do you think DNA has these properties?*

*Q13. Based on what you know about DNA structure, if I used this same procedure to extract DNA from human cells or bacteria, do you think it would look the same or different? Why?*

## Part 4 – DNA Packaging

\*If you run out of time, skip part 4 and go straight to the concept questions at the end.\*

Let's finish up by thinking BIGGER. Your model has 3 nucleotide pairs, but most human cells have *6 billion* of these nucleotide pairs! That's a lot of DNA! Believe it or not, we don't even have the biggest genome on Earth – that belongs to the marbled lungfish (pictured below), which has over 130 billion nucleotide pairs per cell!! In order to fit all that DNA into a cell, it needs to be very tightly **compacted**, or **packaged**.



[https://upload.wikimedia.org/wikipedia/commons/f/f6/Marbled\\_lungfish\\_2.jpg](https://upload.wikimedia.org/wikipedia/commons/f/f6/Marbled_lungfish_2.jpg)

1. Take a piece of sewing thread that's 2 meters long. This is how much DNA is in a *single cell* in your body. Roll it into the tiniest little ball that you can, and measure the diameter (how big it is at the widest part of the ball) using the "cm" (centimeter) scale on the ruler.

*Q14. How big is your ball of thread?*

*Q15. A cell nucleus is about 0.001cm wide. Were you able to get your ball of thread that small?*

This packaging not only helps the DNA to fit into the nucleus, it also helps to control which parts of the DNA are **expressed**, or turned on. Think about it – a blood cell and a muscle cell look very different, and have very different jobs to do (see the pictures below), but they have the exact same DNA! This is because different pieces of the DNA, called **genes**, are turned on or off.

*Q16. Genes are just pieces of the DNA that "make sense" to the cell. So, for example, if I gave you the following message, would you be able to identify the "gene" in it?*

*aeoigblerjoisdrijthispieceofdnaisneededforbrownhairplhseroipwahrpoihrs*

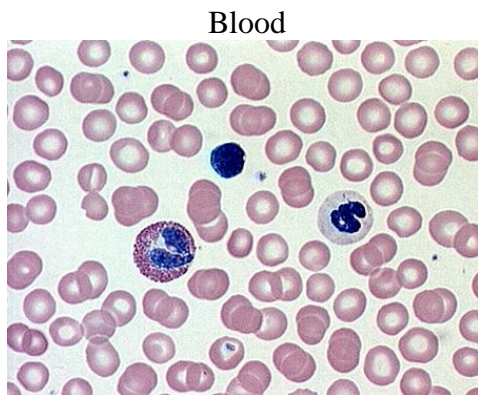

<http://lifesci.rutgers.edu/~babiarez/bloodtx.htm>

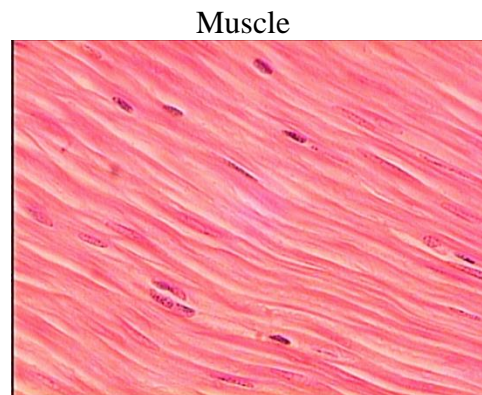

<http://www.gwc.maricopa.edu/class/bio201/Histology/HistoRev22a.htm>

*Q17. Write whether you think each set of genes is "on" or "off" in the different types of cells above.*

	<b>Blood Cell</b>	<b>Muscle Cell</b>
Genes for making antibodies		
Genes for tight cell-cell connections		



(Look at the pictures for help!)		
Genes for making energy		

Just like you can use your ability to read to find the hidden message in the question above, genes are able to be recognized by proteins in the cell which know how to look for them! Once they find a gene, they bind to it and start to communicate that message to the rest of the cell (“Hey guys! We’re supposed to be an eye cell! This gene says we have green eyes!”). In order for this to happen the gene needs to be **accessible**, or opened up and able to be bound. Let’s see how that might happen.

- Your teacher will give you two pieces of string with colored patches on them – let’s say the first patch is a gene for hair color and the patch in the middle is a gene for eye color (see diagram). Lay out one piece flat on the table.



- Have one person in your group slide a ring of tape (sticky side out!) on each pointer finger, and point the fingers at each other, a few inches apart.
- Now have a partner take the second piece of string and wrap it 2 times around the tape ring on one finger **making sure to wrap up the first (hair color) gene**. Then take the other end and wrap it 2 times around the other finger **making sure to keep the second (eye color) gene in the middle exposed** in a loop of loose thread.
- Carefully slide the two tape rings off, and lay the string next to the piece you already have laying on the table.

*Q18. If you were the cell, which form of DNA would you prefer, based on the concepts that we have discussed so far? List two reasons why your choice (wrapped or unwrapped) is better.*

*Q19. Draw a diagram of the wrapped DNA and label which gene (represented by the colored patches) is likely turned on, and which is likely turned off.*

*Q20. Do you think every cell has the DNA wrapped the same way? Why or why not?*

*Q21. If I took skin cells from two unrelated people and analyzed the DNA, would the sequence be the same? Would the packaging of the DNA be the same? Why or why not?*

## Concept Questions:

22. Which of the following do you think contain DNA?

Bananas \_\_\_ Concrete \_\_\_ Meat \_\_\_ Metal \_\_\_ Plastic \_\_\_ Wooden Table \_\_\_

What do the items you picked have in common?

23. The sequence of each person's DNA is different. True / False

Can you think of any exceptions to this statement?

24. Pair these letters with their complementary bases:

A A C T G G T A

25. DNA is compacted:

- a. To make it fit in the cell nucleus
- b. To control which parts of the DNA are being used in different cells
- c. To protect the DNA from damage (like being cut)
- d. All of the above

26. Antibiotics kill bacteria by getting into cells and inactivating specific, essential proteins. However, bacteria can become resistant to antibiotics through acquiring new mutations. Where do these mutations come from? What kinds of genes / proteins do you think are being mutated?

27. Cancer cells try to turn off genes that would normally prevent them from growing and dividing out of control. What are two ways that we learned about that you could "turn off" a gene?